

Advanced Wind Turbine Design



Vortexwindfunnel.com

1233 Tessier St
Hawkesbury Ontario
K6A-3R1 Canada

Phone: 1-613-636-0539
Fax: 1-613-636-0762
E-mail: sales@mflo.com



Designed for light industries and residential user where conventional wind turbines are not feasible due to noise levels, shadowing, bird safety or height restriction. The Mini Vortex Wind Funnel can convert more wind into clean electricity. It's one of the most compact, user-friendly, all-inclusive wind generator (with controls and inverter built in) designed to provide very quiet, clean electricity in low to high wind areas.

With a rated capacity of 1.2 kW and very low startup speed, the Mini Vortex Wind Funnel can help offset a household or small business total energy needs on a more consistent bases. Since it is almost completely noiseless, it does not cause flickering shadows and is bird-safe* (the vortex is solid looking and doesn't cause extreme air turbulence like some three blade turbines) the Mini Vortex Funnel can be situated in more dense populated areas without neighbors complaining.

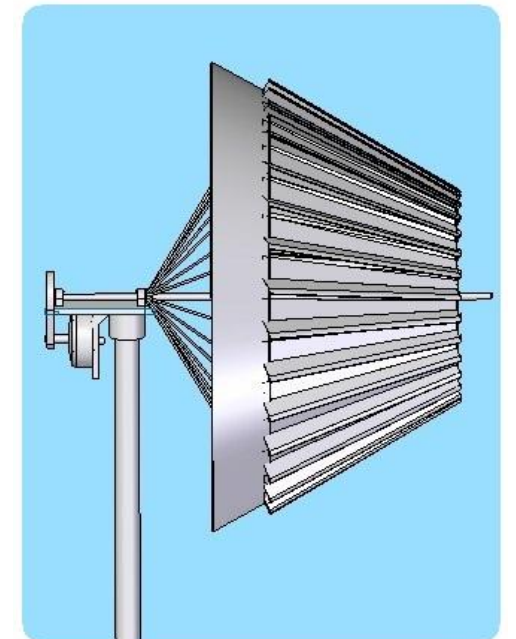

Revolutionary small wind turbine.

Using the conventional three blade technology, the best potential locations for wind power are in remote locations, ocean based, very high elevations or on top of very high poles which makes these potential sources of wind power expensive and less efficient. The Vortex Wind Funnel (VWF) design has changed this paradigm. This patent pending wind turbine not only produces usable energy at winds below 4.5 m/s (10MPH), it also has the amazing characteristic of not being able to over spin at high wind speeds.

Since the Master Flo design will produce usable wind energy at lower and higher wind speeds, it will be running more often thereby creating more energy per year. Simply stated the Vortex Wind Funnel produces more constant power which should mean more power per year and a faster return on investment.



Innovative Design

The Vortex design is engineered to operate in areas with minimum average wind speeds of at least 10 mph (4.5 m/s), though it works best where Wind speeds are variable and in low and high wind speed locations. Wind speeds vary by location, even within a property. Your authorized Master Flo Dealer can discuss site guidelines with you in more detail.

Specifications

Rated Capacity: 1.2 kW
Rotor Diameter: 7.2 ft (2.195 m)
Swept Area: 40.33 ft² (3.77 m²)
Weight: 117 lb (53 kg)
Direction: of Rotation Clockwise looking upwind
Blades: 30 aluminum in a Vortex cone
Rated Speed: 40 - 210 rpm
Generator: Slotless permanent magnet brushless
Yaw Control: Mechanical Passive
Grid Feeding: 120/240 VAC Split 1 Ph, 60 Hz
120/208/240 VAC 1 Ph, 50/60 Hz
Battery Charging: Battery Charge Controller kit is currently unavailable
Braking System: Mechanical Terminal Velocity Design
Cut-in Wind Speed: 4 mph (1.78 m/s)
Electronic: Digital user interface
Survival Wind Speed: 100 mph (44 m/s) estimate
Slip Ring: 360 degree full rotational
Warranty: 5 year limited warranty

1 Data measured and compiled by Master Flo Technology based on the data collected at Master Flo's head office in Hawkesbury Ontario. Actual power output may vary in different areas and all data should be used only as a guide.



Powerful

The Mini Vortex Wind Funnel converts more wind at lower speeds into clean electricity. It is the evolution of wind turbine design. Simply it is one of the most user-friendly, comprehensive wind generator created to provide up to THREE times more energy annually than most conventional three blade units.

Power Curve

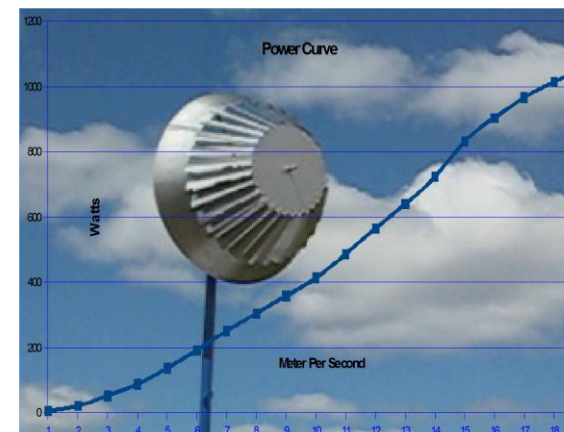

Innovative, Powerful & Environmental

Bird and Bat Friendly
Low Noise Operation
Low Weight
Low startup speeds
Low cost installation possible
Complete wind power system
Innovative, attractive design
Excellent Return on Investment
Many installation options
Turbulent air resistance
Annual energy 2500+ kWh/year
Great Power Output even in extreme wind conditions
Grid-Ready
Integrated inverter
High efficiency generator
UL EU and CSA Certifiable



Wind Technology

1233 Tessier St
Hawkesbury Ontario
K6A-3R1 Canada

Phone: 1-613-636-0539
Fax: 1-613-636-0762
E-mail: sales@mflo.com
Web: vortexwindfunnel.com